



#### Features:

- High Flow rate upto 300 lpm (79.3 USgpm)
- Maximum Operating pressure upto 315 bar (4500 PSI)
- Long service life with average durability of 50 million spool shifts.

**Technical Specifications**

Spool Type & Graphic Symbols		DHG – 04 (1/2")	
Symbols	Model Number	Rated Flow Capacity	Maximum Flow Capacity
	DHG-04-2B2-**	135 lpm (35.7 USgpm)	300 lpm (79.3 USgpm)
	DHG-04-2B3-**		
	DHG-04-2N2-**		
	DHG-04-2N3-**		
	DHG-04-3C2-**		
	DHG-04-3C3-**		
	DHG-04-3C4-**		
	DHG-04-3C40- **		
	DHG-04-3C7-**		
	DHG-04-3C9-**		
	DHG-04-3C10- **		
	DHG-04-3C11- **		
	DHG-04-3C12- **		
	DHG-04-3C5-**	245 lpm (64.8 USgpm)	280 lpm (74.5 USgpm)
	DHG-04-3C6-**		
	DHG-04-3C60- **		
<b>Max. Operating Pressure (P.AB) (bar)</b>		315 (4500 PSI)	
<b>Min. Required Pilot Pressure</b>		8 (114 PSI)	
<b>Max. Pilot Pressure</b>		250 (3600 PSI)	
<b>Max. T-Line Back Pressure (T) (bar)</b>		210 (3000 PSI)	
<b>Weight (Kgs)</b>		7.4 (16.3 lbs)	
<b>Hydraulic Fluids</b>		Use Hydraulic Fluids Equivalent to ISO VG32 or VG46	
<b>Operating Temperature Range (°C)</b>		-15 ~ +70 (+5 ~ +160 °F)	
<b>Operating Viscosity (cSt)</b>		15 ~ 400 (80 ~ 1800 SSU)	
<b>Filtration</b>		25 Microns Absolute or Finer	

## Dimensions

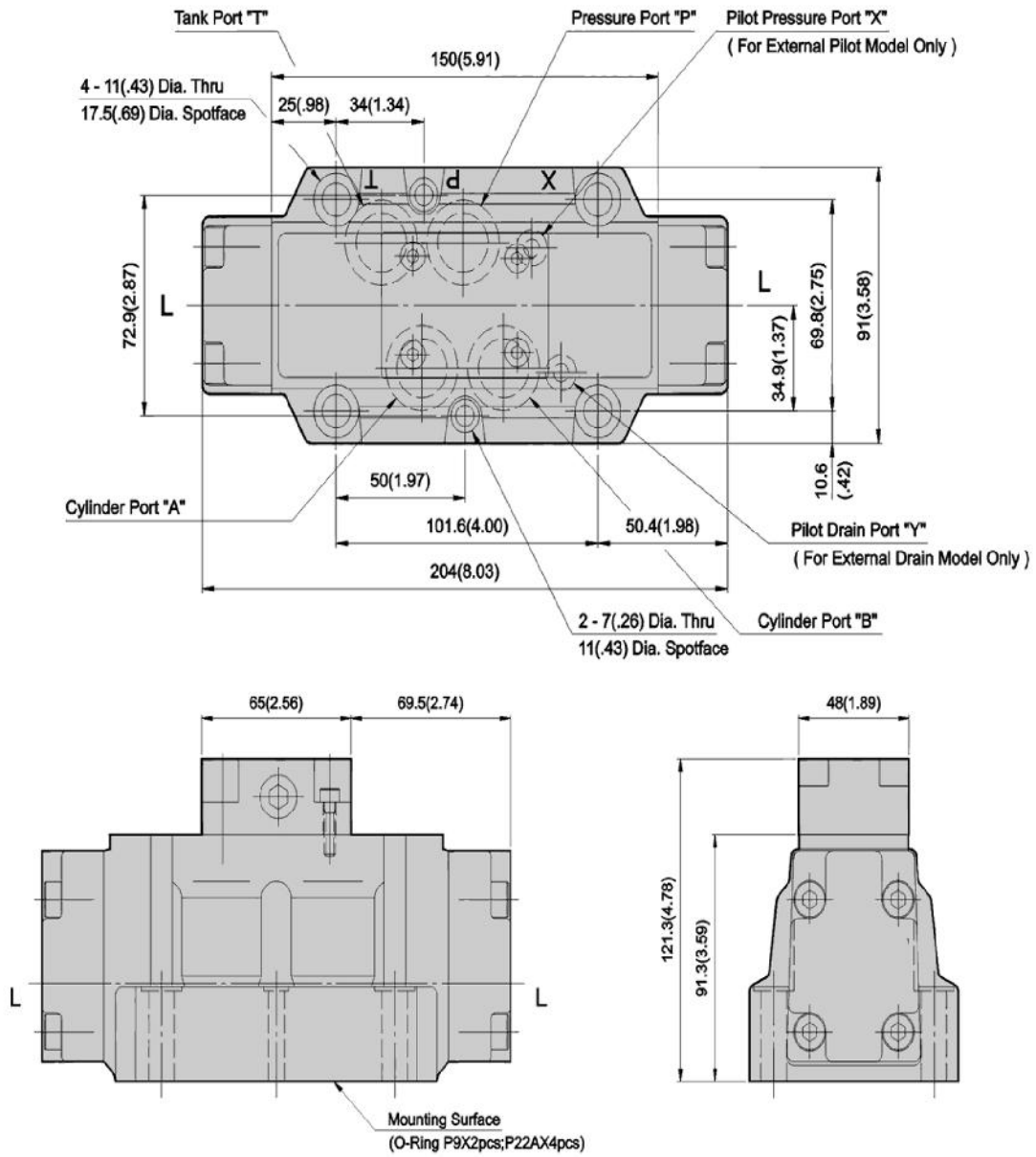

Attachment Name	Description	Tightening Torque	Code
Soc. Hd. Cap Screw	M6X45LgX2pcs	12-15 Nm	30
	M10X45LgX4pcs	58-72 Nm	
Soc. Hd. Cap Screw	1/4-20UNCX1-3/4"LgX2pcs	104-130 in.lbs	3090
	3/8-16UNCX1-3/4"Lg X4pcs	504-625 in.lbs	

## Assembly

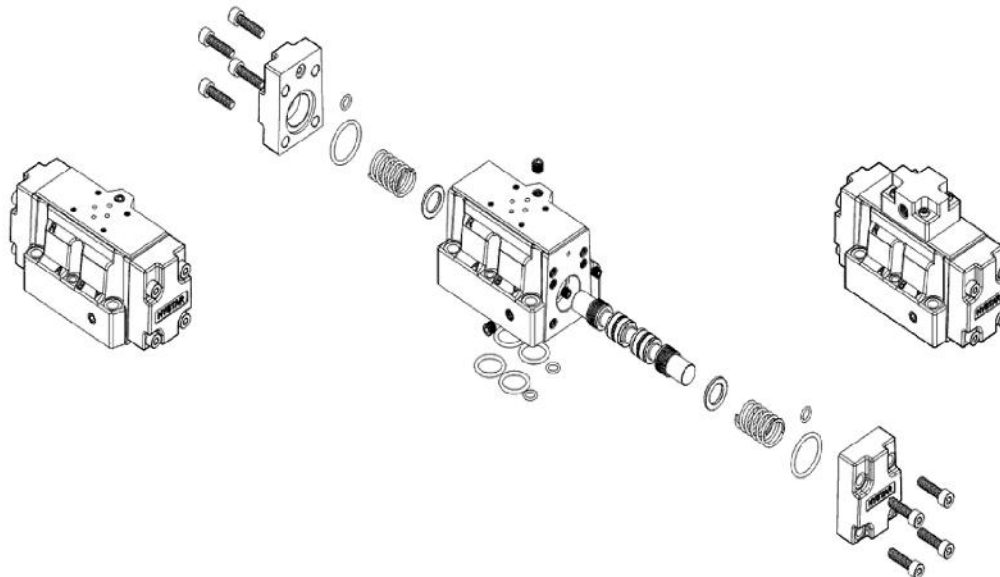

## Ordering Code

DHG	3C2	N	04	D1	36	*P*D
Series No.	Spool Type	Electrical Conduit Type	Valve Size	Coil Voltage	Design No.	Pilot and Drain Connection
DHG	Spring centered 3 Position (3C94, 3C60, 3C6, 3C3 etc.)	N: DIN connector with light.	04 – 1/2" (NFPA-D07)	D1: DC12V D2: DC24V	36: with DIN 912 bolts	*P -> Pilot Plug (1/16, 1/8, 1/4) *D -> Drain Plug (1/16, 1/8, 1/4)
	Spring Offset 2 Position (2B2, 2B3, 2B8, 2B29 etc.)			D3: DC36V D4: DC48V		1P1D: Internal Pilot, Internal Drain
	Spring Detented 2 Position (2D2, 2D3 etc.)			D5: DC60V D6: DC72V		1P2D: Internal Pilot, External Drain
	For complete list see Spool Types tab below			D14.5: DC14.5v D28: DC28V		2P1D: External Pilot, Internal Drain 2P2D: External Pilot, External Drain

## Performance Graph

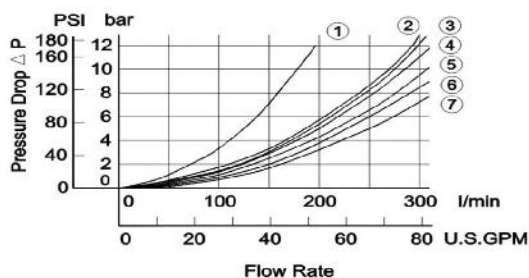

Series	Spool Type	Pressure Drop Curve Number				
		P→A	B→T	P→B	A→T	P→T
DSHG-04 DSHG-04-S	3C2	5 (2)	4 (2)	5 (2)	6 (4)	—
	3C3	5	3	5	5	7
	3C4	5 (2)	3 (3)	5 (2)	5 (5)	—
	3C40	5 (2)	4 (4)	5 (2)	6 (6)	—
	3C5	7	4	5	5	5
	3C6	5 (8)	3 (4)	5 (6)	6 (7)	1 (2)
	3C60	7	6	7	7	2
	3C7	5	4	5	6	—
	3C9	5	4	5	6	—
	3C10	5 (2)	2 (2)	5 (2)	6 (4)	—
	3C11	6	4	5	6	—
	3C12	5 (2)	4 (2)	5 (2)	5 (5)	—

Graphs based on fluid viscosity of 35 cSt ( 162 SSU).  
Notes : ( ) curve No. is for shock-less type.

## Sub Plate

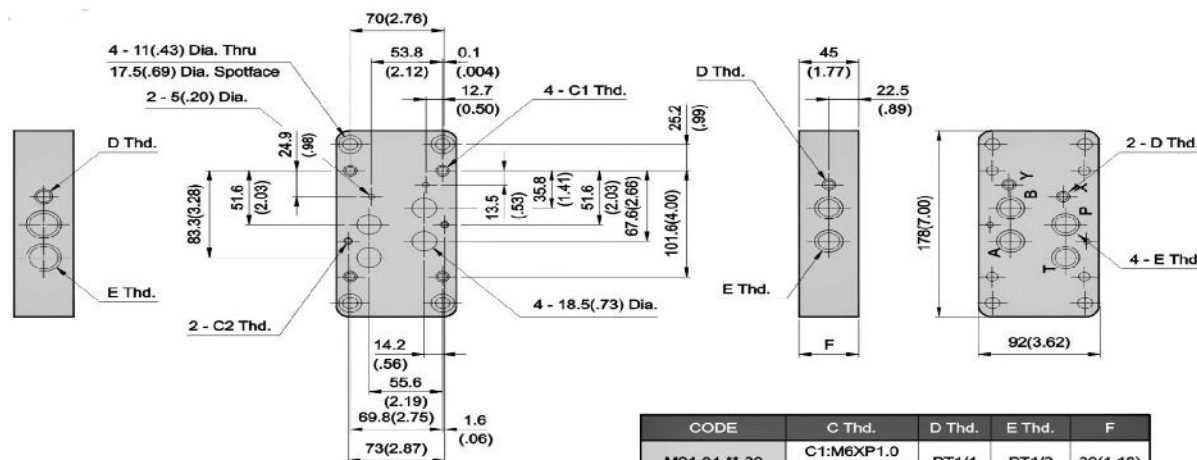

CODE	C Thd.	D Thd.	E Thd.	F
M04-04-**-30	C1:M6XP1.0	PT1/4	PT1/2	30(1.18)
	C2:M10XP1.25			
M04-04-**-3090	C1:1/4-20UNC	NPT1/4	NPT1/2	30(1.18)
	C2:3/8-16UNC			
M04-06-**-30	C1:M6XP1.0	PT3/8	PT3/4	—
	C2:M10XP1.25			
M04-06-**-3090	C1:1/4-20UNC	NPT3/8	NPT3/4	—
	C2:3/8-16UNC			

"F" is for port position "4B" type only.